



# Gas Furnaces 80AF

## PRODUCT SPECIFICATIONS

### INSTALLATION OPTIONS

- Available in Upflow/Horizontal and Counterflow models

### HEAT EXCHANGER

- Aluminized steel tapered design primary heat exchanger with crimped construction for long life

### BURNERS

- Aluminized steel inshot burners for smooth combustion

### CABINET CONSTRUCTION

- Unitized construction for cabinet integrity
- Bottom or side return air
- Baked on pre-painted steel cabinet finish
- Left or right side gas and electric entry

### BLOWER

- Easily removable slide-out blower design
- PSC multi-speed permanently lubricated blower motor for low maintenance and optimum efficiency

### CONTROLS

- Single stage gas valve
- Integrated ignition and fan control board features self diagnostics
- Hot surface ignitor

### VENTING

- Permanently lubricated draft motor is air cooled for long life
- "L" designated units comply with California's South Coast Air Quality Management District Low NOx requirements

**80% AFUE**  
**44,000 to 132,000 Btuh Input**  
**1.5 to 5 Tons Add-On Cooling**



Upflow /  
Horizontal



Counterflow

### Warranty

Heat Exchanger - 20 Year Limited  
Parts - 5 Year Limited

# Gas Furnaces

## 80AF

### Model Number Identification

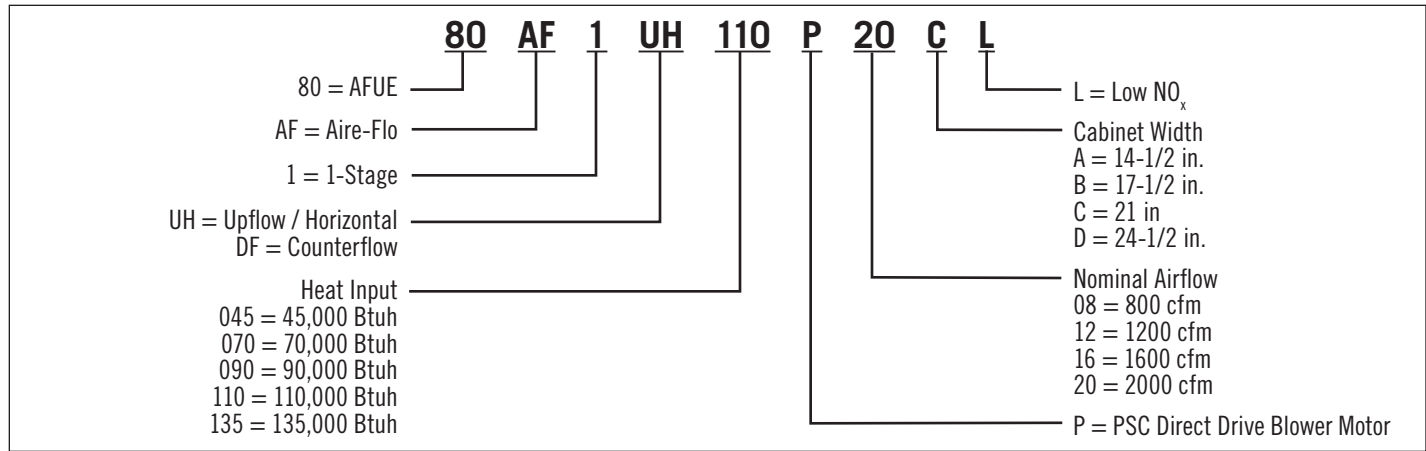

### Specifications

Model No. Model No. - Low Nox	80AF1UH045P12A	80AF1UH070P12A	80AF1UH090P12B	80AF1UH090P16B	80AF1UH110P16C	80AF1UH110P20C
	80AF1UH045P12AL	80AF1UH070P12AL	- - -	80AF1UH090P16BL	- - -	80AF1UH110P20CL
	Upflow / Horiz.	Upflow / Horiz.	Upflow / Horiz.	Upflow / Horiz.	Upflow / Horiz.	Upflow / Horiz.
Input Btuh	44,000	66,000	88,000	88,000	110,000	110,000
Output Btuh	35,000	54,000	71,000	71,000	89,000	89,000
AFUE (Isolated Comb. System)	80%	80%	80%	80%	80%	80%
Temperature Rise (°F)	40 - 70	40 - 70	40 - 70	40 - 70	35 - 65	65 - 65
Gas Pipe Size (in.)	1/2	1/2	1/2	1/2	1/2	1/2
Flue Connection in. (diameter)	4	4	4	4	4	4
Volts/Hertz/Phase	120/60/1	120/60/1	120/60/1	120/60/1	120/60/1	120/60/1
Blower Motor Horsepower	1/5	1/5	1/3	1/2	1/2	1
Add-On Cooling (tons)	2-3	2-3	2-3	3-4	3-4	4-5
Circuit Breaker or Fuse	15	15	15	15	15	15
Full Load Amps	3.1	3.1	6.1	8.2	8.2	10
Blower Wheel Size (Dia. x Width)	10 x 7	10 x 7	10 x 9	10 x 10	10 x 10	11½ x 10
Shipping Weight (lbs.)	105	114	131	183	151	161

### Specifications

Model No.	80AF1UH135P20D	80AF1DF045P12A	80AF1DF070P12A	80AF1DF090P16B	80AF1DF110P20C
	Upflow / Horiz.	Counterflow	Counterflow	Counterflow	Counterflow
Input Btuh	132,000	44,000	66,000	88,000	110,000
Output Btuh	107,000	35,000	54,000	71,000	89,000
AFUE (Isolated Comb. System)	80%	80%	80%	80%	80%
Temperature Rise (°F)	40 - 70	15 - 45	25 - 55	25 - 55	30 - 60
Gas Pipe Size (in.)	1/2	1/2	1/2	1/2	1/2
Flue Connection in. (diameter)	4	4	4	4	4
Volts/Hertz/Phase	120/60/1	120/60/1	120/60/1	120/60/1	120/60/1
Blower Motor Horsepower	1	1/3	1/3	1/2	3/4
Add-On Cooling (tons)	4-5	2-3	2-3	3-4	4-5
Circuit Breaker or Fuse	15	15	15	15	15
Full Load Amps	11.5	6.1	6.1	8.2	10.0
Blower Wheel Size (Dia. x Width)	11 x 11	10 x 8	10 x 8	10 x 10	11½ x 10
Shipping Weight (lbs.)	174	112	121	140	163

# Gas Furnaces

## 80AF

### Accessories - Upflow / Horizontal

Model No.		80AF1UH045P12A 80AF1UH070P12A	80AF1UH090P12B 80AF1UH090P16B	80AF1UH110P16C 80AF1UH110P20C	80AF1UH135P20D	
		Upflow / Horizontal	Upflow / Horizontal	Upflow / Horizontal	Upflow / Horizontal	
<b>CABINET</b>						
Horizontal Suspension Kit (Horizontal)		51W10	51W10	51W10	51W10	
Return Air Base (Upflow)		68W81	68W62	68W63	68W64	
<b>FILTER KITS</b>						
<sup>1</sup> Air Filter and Rack Kit (Upflow/Horizontal)	Horizontal (end)		87L95 (14 x 25 x 1)	87L96 (18 x 25 x 1)	87L97 (20 x 25 x 1)	87L98 (25 x 25 x 1)
	Side Return (Upflow)	Single	44J22	44J22	44J22	44J22
		10-pack	66K63	66K63	66K63	66K63
		Size	16 x 25 x 1	16 x 25 x 1	16 x 25 x 1	16 x 25 x 1
<b>GAS HEATING</b>						
High Altitude Pressure Switch Kit	0-4500 ft.	No Change	No Change	No Change	No Change	
	4501-7500 ft.	80W52 (045, 070)	80W52 (090)	80W57 (110)	80W57 (135)	
	7501-10,000 ft.	80W51 (045, 070)	80W51 (090)	80W52 (110)	80W51 (135)	
Natural to LP Conversion Kit	0-7500 ft.	70W89	70W89	70W89	70W89	
	7501-10,000 ft.	76W15	76W15	76W15	76W15	
LP to Natural Conversion Kit	0-7500 ft.	73W81	73W81	73W81	73W81	
Natural Gas High Altitude Orifice Kit	7501-10,000 ft.	73W37	73W37	73W37	73W37	
<b>NIGHT SERVICE KIT</b>						
Night Service Kit		68W80	68W80	68W80	68W80	
<b>VENTING</b>						
Vent Adaptor – 6 in. conn. size upflow applications only		18M79	18M79	18M79	18M79	

<sup>1</sup> Cleanable polyurethane frame type filter.

### Accessories - Counterflow

Model No.		80AF1DF045P12A 80AF1DF070P12A	80AF1DF090P16B	80AF1DF110P20C
		Counterflow	Counterflow	Counterflow
<b>CABINET</b>				
Combustible Flooring Base (Counterflow)		11M59	11M60	11M61
<b>FILTER KITS</b>				
<sup>1</sup> Air Filter and Rack Kit (Counterflow)		51W06 ((1) 20 x 16 x 1)	51W07 (2) 20 x 20 x 1	51W08 (2) 20 x 20 x 1
<b>GAS HEATING</b>				
High Altitude Pressure Switch Kit	4501-7500 ft.	80W52 (045, 070)	80W52 (090)	80W57 (110)
	7501-10,000 ft.	80W51 (045, 070)	80W51 (090)	80W52 (110)
Natural to LP Conversion Kit	0-7500 ft.	70W89	70W89	70W89
	7501-10,000 ft.	76W15	76W15	76W15
LP to Natural Conversion Kit	0-7500 ft.	73W81	73W81	73W81
LP High Altitude Orifice Kit	7501-10,000 ft.	73W37	73W37	73W37
<b>NIGHT SERVICE KIT</b>				
Night Service Kit		68W80	68W80	68W80

<sup>1</sup> Cleanable polyurethane frame type filter.

# Gas Furnaces

## 80AF

### Blower Data

Model No.	Blower Speed	<sup>1</sup> CFM @ External Static Pressure - in w.c. Less Filter									
		.00	.10	.20	.30	.40	.50	.60	.70	.80	.90
80AF1UH045P12A (Upflow / Horizontal)	High	1663	1613	1563	1518	1463	1393	1323	1218	1128	1013
	Med/High	1328	1328	1323	1308	1268	1228	1178	1128	1003	923
	Med/Low	1133	1123	1108	1133	1118	1078	1043	988	918	813
	Low	918	933	943	943	938	918	878	833	778	643
80AF1UH070P12A (Upflow / Horizontal)	High	1653	1613	1573	1513	1473	1393	1333	1238	1153	1038
	Med/High	1363	1358	1348	1328	1293	1263	1198	1118	1038	933
	Med/Low	1088	1108	1128	1123	1093	1073	1028	968	908	823
	Low	928	938	953	948	938	918	873	828	768	778
80AF1UH090P12B (Upflow / Horizontal)	High	1788	1753	1718	1678	1623	1528	1463	1358	1248	1153
	Med/High	1443	1428	1413	1403	1363	1308	1268	1178	1098	993
	Med/Low	1188	1178	1163	1163	1143	1118	1078	1013	928	808
	Low	963	963	968	973	948	918	903	833	778	673
80AF1UH090P16B (Upflow / Horizontal)	High	2153	2023	1903	1833	1763	1658	1578	1463	1348	1193
	Med/High	1818	1773	1733	1698	1628	1553	1463	1358	1223	1113
	Med/Low	1508	1518	1528	1493	1453	1403	1323	1253	1148	1013
	Low	1253	1273	1298	1298	1273	1218	1183	1108	1013	913
80AF1UH110P16C (Upflow / Horizontal)	High	2163	2118	2073	2008	1933	1843	1768	1673	1553	1418
	Med/High	1838	1813	1783	1738	1688	1628	1568	1463	1343	1183
	Med/Low	1558	1548	1533	1538	1498	1463	1388	1313	1198	1053
	Low	1263	1293	1328	1328	1313	1288	1228	1163	1043	903
80AF1UH110P20C (Upflow / Horizontal) Single Side Return Air - Air volumes in bold require field fabricated transition to accommodate 20 x 25 x 1 in. air filter in order to maintain proper air velocity.	High	<b>2708</b>	<b>2598</b>	<b>2498</b>	<b>2428</b>	<b>2343</b>	<b>2253</b>	<b>2168</b>	<b>2078</b>	<b>1958</b>	<b>1823</b>
	Med/High	2168	2153	2143	2108	2063	2003	1948	1843	1778	1693
	Med/Low	1688	1733	1778	1788	1798	1778	1748	1703	1633	1548
	Low	1403	1423	1443	1478	1473	1473	1483	1453	1418	1348
Bottom Return Air, Side Return Air with Optional Return Air Base, Return Air from Both Sides or Return Air from Bottom and One Side.	High	2568	2513	2458	2378	2288	2193	2123	2008	1898	1788
	Med/High	2263	2243	2223	2173	2098	2048	1978	1883	1803	1703
	Med/Low	1838	1853	1863	1878	1858	1838	1788	1713	1668	1538
	Low	1423	1448	1473	1533	1563	1563	1543	1498	1463	1368
80AF1UH135P20D (Upflow / Horizontal) Single Side Return Air - Air volumes in bold require field fabricated transition to accommodate 20 x 25 x 1 in. air filter in order to maintain proper air velocity.	High	<b>2803</b>	<b>2718</b>	<b>2633</b>	<b>2568</b>	<b>2488</b>	<b>2398</b>	<b>2298</b>	<b>2208</b>	<b>2103</b>	<b>1978</b>
	Med/High	<b>2178</b>	<b>2173</b>	<b>2173</b>	<b>2158</b>	<b>2138</b>	<b>2098</b>	<b>2038</b>	<b>1963</b>	<b>1883</b>	1783
	Med/Low	1698	1708	1713	1783	1768	1773	1768	1733	1668	1593
	Low	1253	1313	1373	1413	1443	1463	1473	1448	1423	1373
Bottom Return Air, Side Return Air with Optional Return Air Base, Return Air from Both Sides or Return Air from Bottom and One Side.	High	2778	2743	2713	2598	2488	2413	2328	2213	2113	1978
	Med/High	2198	2213	2228	2213	2178	2128	2073	1988	1883	1783
	Med/Low	1658	1718	1778	1813	1838	1818	1818	1753	1673	1598
	Low	1338	1388	1438	1453	1478	1498	1488	1468	1428	1383

Notes:

<sup>1</sup> Maximum approved external static pressure is 0.50 in. w.c.

# Gas Furnaces

## 80AF

### Blower Data

Model No.	Blower Speed	<sup>1</sup> CFM @ External Static Pressure - in w.c. Less Filter									
		.00	.10	.20	.30	.40	.50	.60	.70	.80	.90
80AF1DF045P12A (Counterflow)	High	1613	1518	1458	1408	1338	1248	1198	1133	1023	918
	Med/High	1478	1378	1343	1288	1228	1183	1098	1053	953	843
	Med/Low	1228	1138	1123	1103	1078	1033	993	938	863	758
	Low	1033	938	938	943	938	888	863	808	733	648
80AF1DF070P12A (Counterflow)	High	1673	1553	1498	1453	1383	1298	1208	1133	1033	918
	Med/High	1488	1378	1348	1308	1258	1193	1123	1058	968	858
	Med/Low	1263	1153	1143	1113	1073	1043	978	893	828	718
	Low	1043	948	948	933	908	898	843	793	708	623
80AF1DF090P16B (Counterflow)	High	2083	1923	1858	1773	1688	1588	1478	1333	1213	1058
	Med/High	1948	1788	1738	1668	1593	1493	1408	1268	1133	998
	Med/Low	1733	1578	1538	1488	1438	1358	1253	1143	1013	898
	Low	1468	1323	1313	1288	1258	1203	1143	1033	908	803
80AF1DF110P20C (Counterflow)	High	2858	2753	2663	2548	2528	2378	2268	2188	2108	1983
	Med/High	2428	2318	2313	2248	2213	2143	2058	2013	1943	1818
	Med/Low	1998	1883	1928	1938	1928	1913	1878	1813	1743	1658
	Low	1598	1523	1558	1598	1613	1618	1608	1568	1508	1468

Notes:

<sup>1</sup> Maximum approved external static pressure is 0.50 in. w.c.

### Clearance to Combustibles (in.)

#### UPFLOW / COUNTERFLOW POSITION

Vent Type	Type B1	Type C
Sides	0	<sup>1</sup> 0
Rear	0	0
Top	1	1
Front	2-1/4	2-1/4
Front (service/alcove)	24	24
Floor	Combustible	Combustible
Flue	1 (25)	6 (152)

NOTE – Air for combustion must conform to the methods outlined in the National Fuel Gas Code (NFPA 54/ANSI-Z223.1).

NOTE – In the U.S. flue sizing must conform to the methods outlined in the current National Fuel Gas Code (NFPA 54/ANSI-Z223.1) or applicable provisions of local building codes.

<sup>1</sup> Left side requires 4 in. if single wall vent is used on 14-1/2 in. cabinets, 2 in. on 17-1/2 in. cabinets.

#### HORIZONTAL POSITION

Vent Type	Type B1	Type C
End	<sup>1</sup> 2	<sup>1</sup> 2
Rear	0	0
Top	<sup>1</sup> 0	<sup>1</sup> 0
Front	2-1/4	2-1/4
Front (service)	24	24
Floor	Combustible	Combustible
Flue	1	6

NOTE – Air for combustion must conform to the methods outlined in the National Fuel Gas Code (NFPA 54/ANSI-Z223.1).

NOTE – In the U.S. flue sizing must conform to the methods outlined in the current National Fuel Gas Code (NFPA 54/ANSI-Z223.1) or applicable provisions of local building codes.

<sup>1</sup> Line contact installation permissible between jacket top or sides and building joists.

# Gas Furnaces 80AF

## Dimensions - inches (mm) Upflow

<sup>1</sup> NOTE - 20C and 20D size units that require second stage air volumes over 1800 cfm (850 L/s) must have one of the following:

1. Single side return air with transition, to accommodate 20 x 25 x 1 in. (508 x 635 x 25 mm) cleanable air filter. Required to maintain proper air velocity.
  2. Single side return air with optional Return Air Base
  3. Bottom return air.
  4. Return air from both sides.
  5. Bottom and      one side return air.
- See Blower Performance Tables for additional information.

<sup>2</sup> Flue outlet may be horizontal but furnace must be vented vertically

<sup>3</sup> Optional External Side Return Air Filter Kit is not for use with the optional Return Air Base.

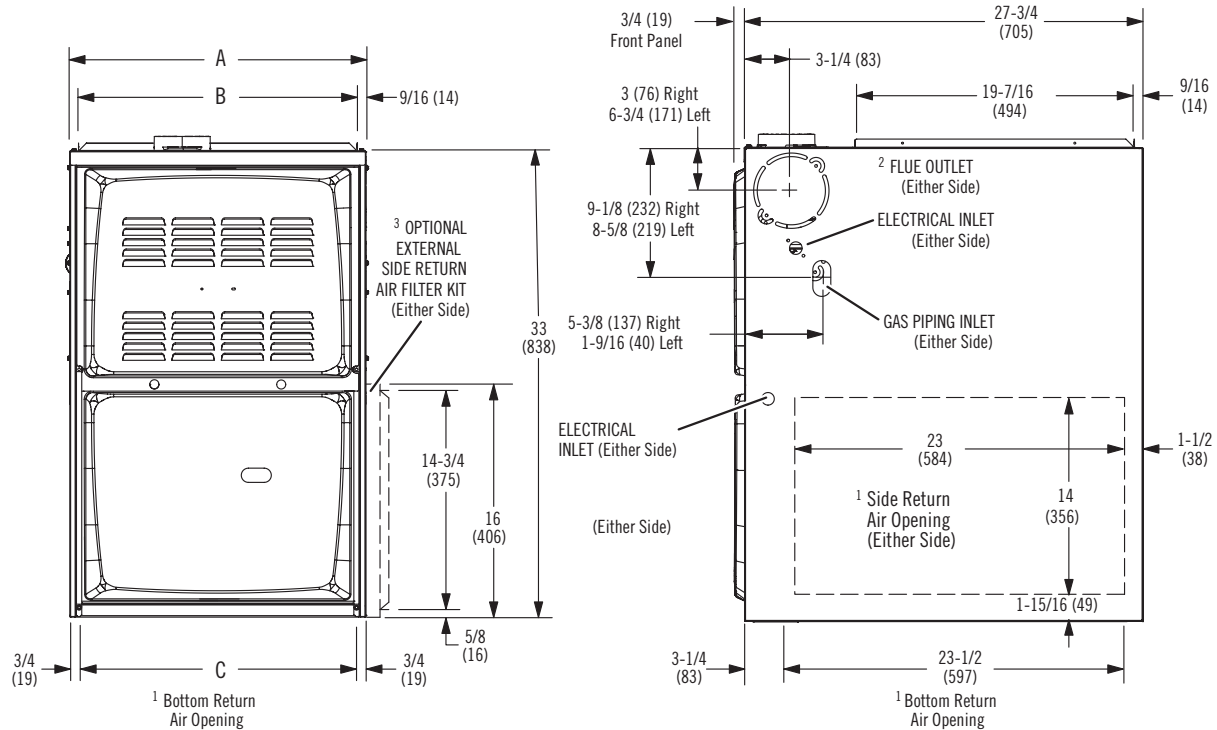
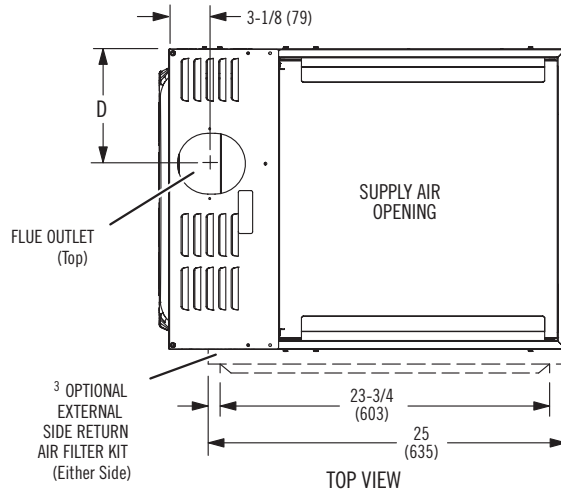

Model No.	A		B		C		D	
	in.	mm	in.	mm	in.	mm	in.	mm
80AF1UH045P12A 80AF1UH070P12A	14-1/2	368	13-3/8	340	13	330	4-3/4	121
80AF1UH090P12B 80AF1UH090P16B	17-1/2	446	16-3/8	416	16	406	7-5/8	194
80AF1UH110P16C 80AF1UH110P20C	21	533	19-7/8	505	19-1/2	495	9-3/8	238
80AF1UH135P20D	24-1/2	622	23-3/8	594	23	584	11-1/8	283

# Gas Furnaces 80AF

## Dimensions - inches (mm) Horizontal

### LEFT-HAND AIR DISCHARGE

<sup>1</sup> Flue outlet may be from end but furnace must be vented vertically

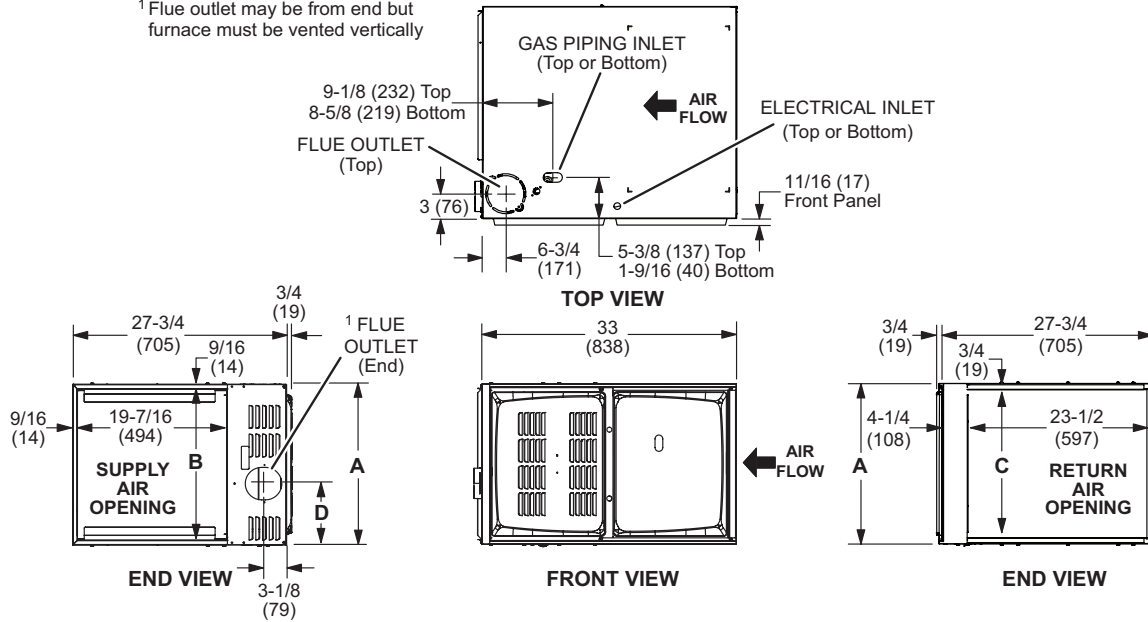

### RIGHT-HAND AIR DISCHARGE

<sup>1</sup> Flue outlet may be horizontal but furnace must be vented vertically

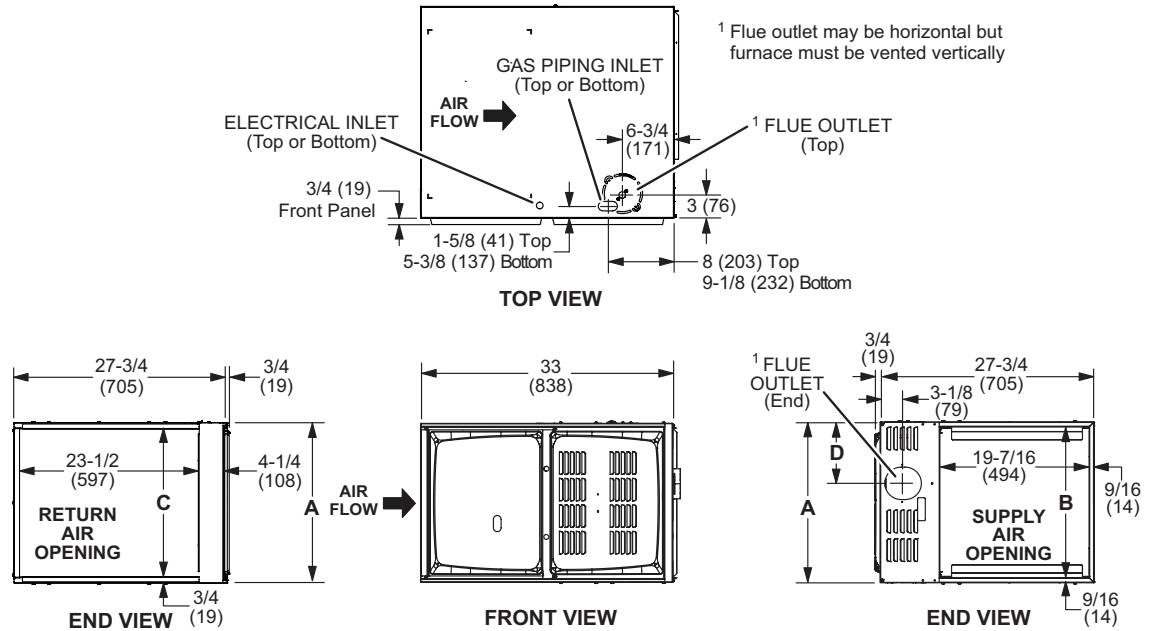

Model No.	A		B		C		D	
	in.	mm	in.	mm	in.	mm	in.	mm
80AF1UH045P12A 80AF1UH070P12A	14-1/2	368	13-3/8	340	13	330	4-3/4	121
80AF1UH090P12B 80AF1UH090P16B	17-1/2	446	16-3/8	416	16	406	7-5/8	194
80AF1UH110P16C 80AF1UH110P20C	21	533	19-7/8	505	19-1/2	495	9-3/8	238
80AF1UH135P20D	24-1/2	622	23-3/8	594	23	584	11-1/8	283

# Gas Furnaces 80AF

## Dimensions - in. (mm) Counterflow

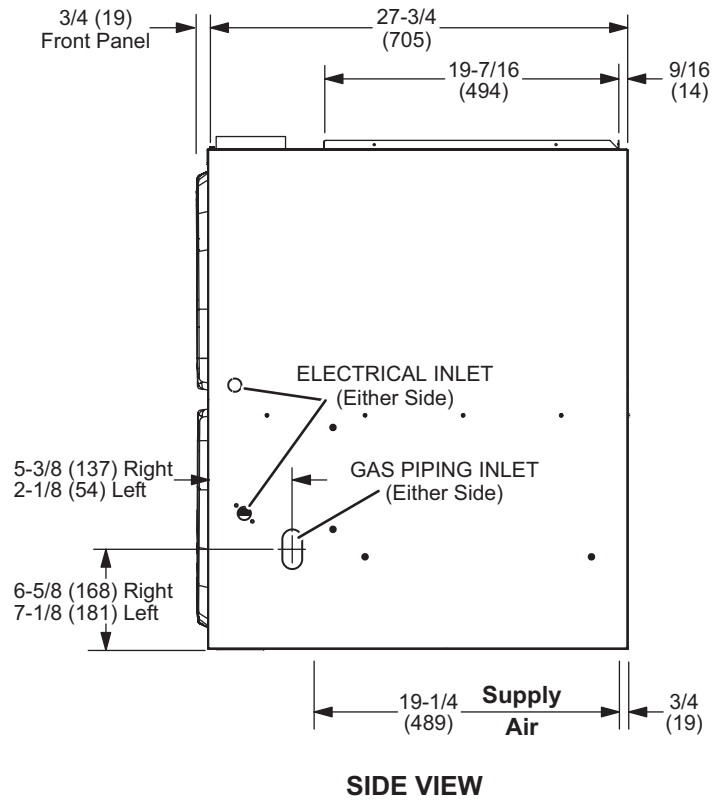
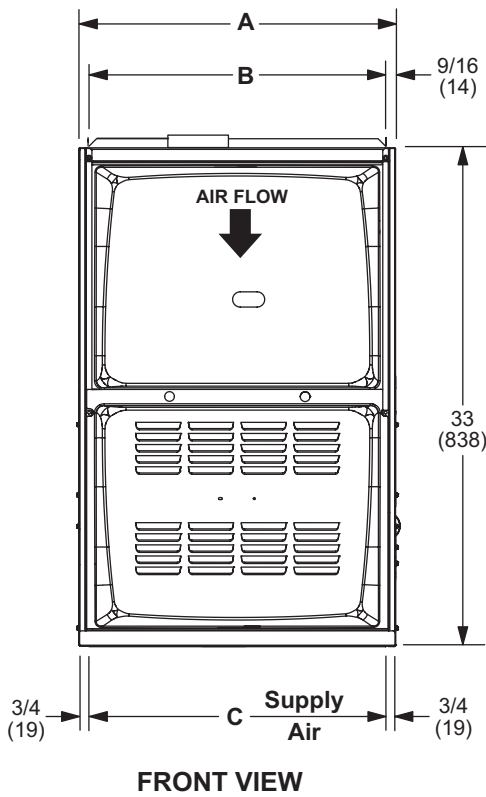
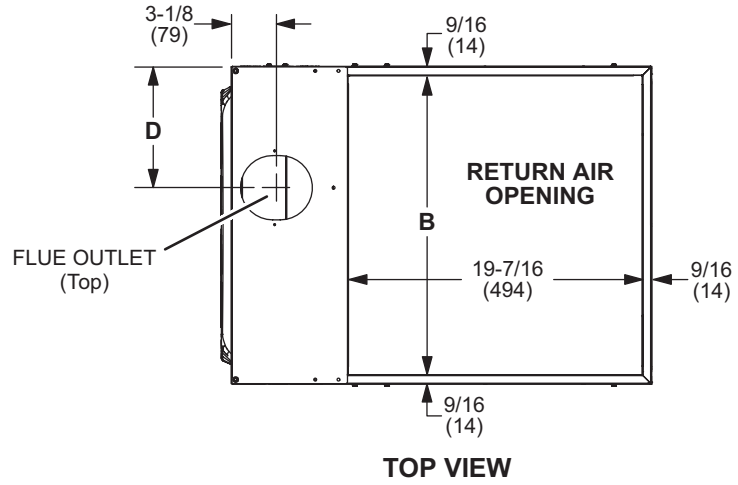

Model No.	A		B		C		D	
	in.	mm	in.	mm	in.	mm	in.	mm
80AF1DF045P12A 80AF1DF070P12A	14-1/2	368	13-3/8	340	13	330	4-3/4	121
80AF1DF090P16B	17-1/2	446	16-3/8	416	16	406	6-1/4	159
80AF1DF110P20C	21	533	19-7/8	505	19-1/2	495	8	203









# Gas Furnaces

## 80AF

### Revisions

Sections	Description of Change
Accessories	Updated Return Air Base catalog numbers.



1.800.982.2333  
www.aireflo-hvac.com



210599 (01/12)



© Aire-Flo Heating and Cooling, 2012